

PATRIOT

Gas Countertop Griddle

FMECTG-24/NG
FMECTG-36/NG
FMECTG-48/NG

Patriot's gas countertop griddles

are designed for use with either natural or LP gas. Constructed of a stainless steel front with galvanized sides. These units are able to stand the toughest of kitchen environments. Each unit includes tips for field conversion to LPG.



Standard Features

- Stainless steel front bullnose design
- Fully welded stainless steel backsplash for extra durability
- 30,000 BTU per burner
- One U-shape burner for every 12" griddle width
- Griddle plate is made up of 5/8" thick steel (3/4" for FMECTG-48 model)
- 3" wide grease trough for easy cleaning
- 4"-5" adjustable legs
- Separate gas valves for each burner with standing pilot ignition system
- Removable stainless steel drip tray for easy cleaning
- 3/4" rear NPT gas inlet
- ETL Listed and ETL Sanitation

Specifications



Model	Overall Width	Burners	Total BTU	Net Weight	Gross Weight
FMECTG-24/NG	24"	2	60,000	114 lbs	147 lbs
FMECTG-36/NG	36"	3	90,000	176 lbs	211 lbs
FMECTG-48/NG	48"	4	120,000	297 lbs	421 lbs

PATRIOT

Gas Countertop Griddle

FMECTG-24/NG, FMECTG-36/NG, FMECTG-48/NG

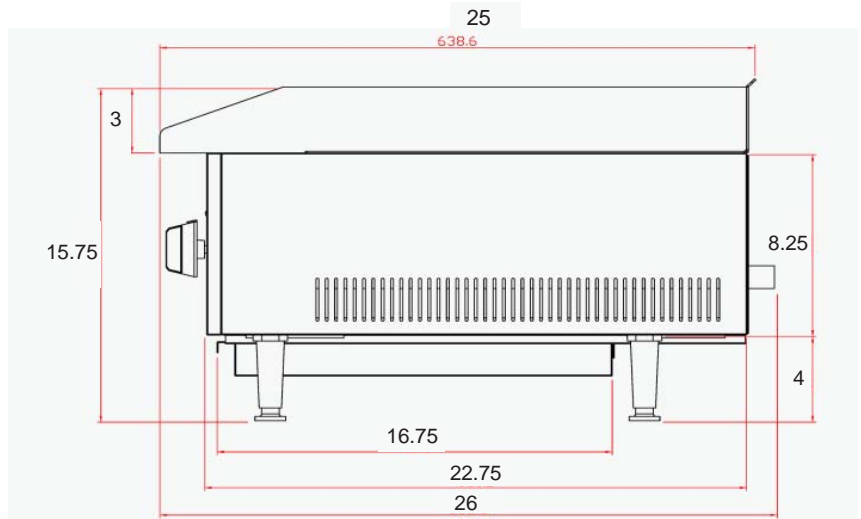
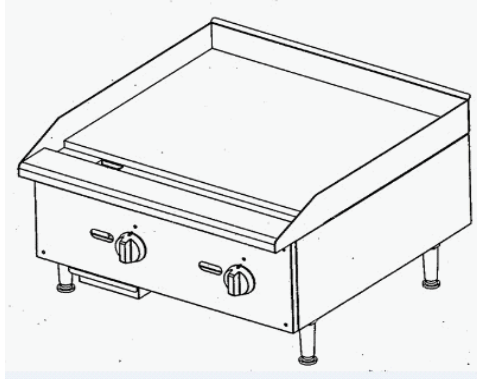

Unit Dimensions (inches)

Model	Description	Width	Depth	Height
FMECTG-24/NG	24" Griddle	24	26	15.75
FMECTG-36/NG	36" Griddle	36	26	15.75
FMECTG-48/NG	48" Griddle	48	26	15.75

Drip Tray (inches)

Model	Width	Depth	Height	Drip Tray Qty
FMECTG-24/NG	6.25	16.75	3	1
FMECTG-36/NG	6.25	16.75	3	1
FMECTG-48/NG	6.25	16.75	3	1

Warranty

Patriot warrants this product to be free of defects in materials and workmanship for period of 3 years from the date of original installation.